

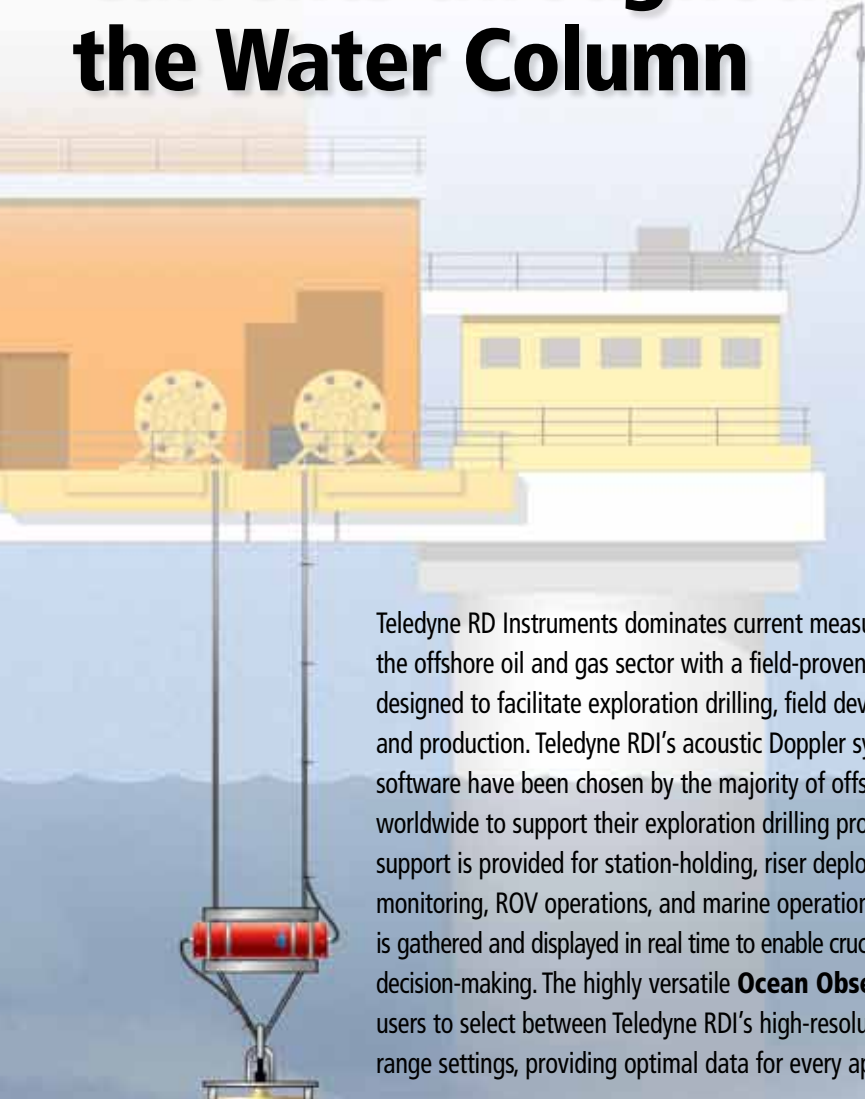

Ocean Observer

STATIONARY PLATFORM ADCP

Remotely Monitor Ocean Currents throughout the Water Column



Teledyne RD Instruments dominates current measurement for the offshore oil and gas sector with a field-proven instrument designed to facilitate exploration drilling, field development, and production. Teledyne RDI's acoustic Doppler systems and software have been chosen by the majority of offshore operators worldwide to support their exploration drilling programs. This support is provided for station-holding, riser deployment and monitoring, ROV operations, and marine operations. Current data is gathered and displayed in real time to enable crucial operational decision-making. The highly versatile **Ocean Observer** allows users to select between Teledyne RDI's high-resolution and long-range settings, providing optimal data for every application.

Frequency	Range (m)	Cell Size (m)
38kHz	>1000	24
75kHz	700	16
150kHz	400	8

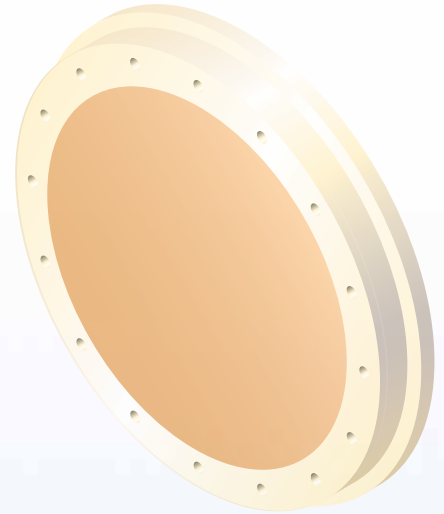

The only platform-mounted ADCP to provide:

- The deepest current profiling available to assist in production and rig safety.
- Two forms of signal processing Broadband for high precision; standard Narrowband for extended range.
- Field-proven technology that operates in the high-noise environment of oil platform production.
- A track record second to none; the Ocean Observer has been adopted by all the major oil companies on every type of platform.
- Patented phased-array transducer, for extended range in a powerful yet compact package.

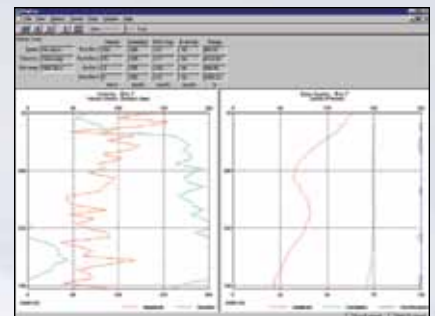

TELEDYNE RD INSTRUMENTS

A Teledyne Technologies Company

MEASURING WATER IN MOTION AND MOTION IN WATER

Ocean Observer

STATIONARY PLATFORM ADCP

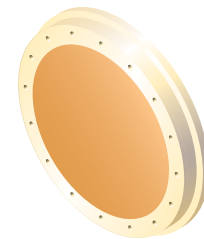

Technical Specifications

Water Profiling						
Long Range Mode	38kHz		75kHz		150kHz	
Vertical Resolution	Max		Max		Max	
Cell Size ¹ (m)	Range ² (m)	Precision ³ (cm/s)	Range ² (m)	Precision ³ (cm/s)	Range ² (m)	Precision ³ (cm/s)
4					350	30
8			650	30	400	17
16	>1000	30	700	17		
24	>1000	20				
High Precision Mode	38kHz		75kHz		150kHz	
Vertical Resolution	Max		Max		Max	
Cell Size ¹ (m)	Range ² (m)	Precision ³ (cm/s)	Range ² (m)	Precision ³ (cm/s)	Range ² (m)	Precision ³ (cm/s)
4					250	12
8			430	12	275	8
16	730	12	450	8		
24	780	9				

¹User's choice of depth cell size is not limited to the typical values specified.

²Ranges are typical and vary with situation.

³Single-ping standard deviation.

Profile Parameters

Velocity accuracy (typical):

±1.0% ± 0.5cm/s

Velocity range: ±7m/s

Number of depth cells: 1–128

Maximum ping rate (Hz):

38kHz	75kHz	150kHz
0.4	0.7	1.5

Bottom Track

Maximum altitude (precision <2cm/s):

38kHz	75kHz	150kHz
1700m	950m	600m

Range accuracy = <±2% actual range*

Echo Intensity Profile

Dynamic range: 80dB

Precision: ± 1.5dB

* Excludes errors introduced by changes in speed of sound profile, by tilting of transducer, and by slope of bottom.

Transducer and Hardware

Beam angle: 30°

Configuration: 4-beam, phased array

Communications: RS-232 or RS-422 at 1200-115,200 baud Hex-ASCII or binary.

System Power

AC input: 90–250VAC, 47–63Hz

Power: 1400W

Software

Use Teledyne RDI's Windows™-based software for the best results; VMDAS—Vessel Mount Data Acquisition System; WinADCP—Data Display and Export

Environmental

Operating temperature: -5° to 45°C

Storage temperature: -30° to 60°C

Standard depth rating: 100m

Standard Sensors

Temperature (mounted on transducer):

Range: -5° to 45°C

Precision: ±0.1°C

Resolution: 0.03°

Tilt:

Range: ±50°

Accuracy: ±1.0°

Precision: ±0.1°

Resolution: 0.1°

Compass (fluxgate type):

Accuracy: ±5° (up to ±20° tilt)

Precision: ±0.3°

Resolution: 0.01°

Maximum tilt: ±50°

System Components

- 38, 75, or 150kHz transducer
- Underwater electronic assembly
- Topside I/F box
- 2 x 5m transducer to underwater electronic assembly cables
- 100m power and communications cable (300m cable optional)

User may supply external compass input or GPS navigation data and NMEA tilt info.

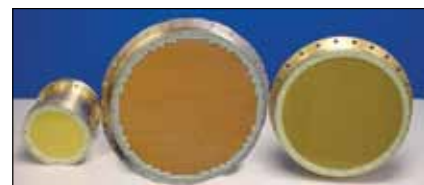

UW Electronic Assembly



Topside I/F Box

Dimensions

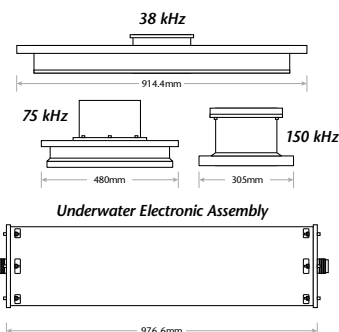

TELEDYNE
RD INSTRUMENTS

A Teledyne Technologies Company

www.rdinstruments.com



Free 24/7 emergency support

Teledyne RD Instruments

14020 Stowe Drive, Poway, CA 92064 USA

Tel. +1-858-842-2600 • Fax +1-858-842-2822 • E-mail: rdisales@teledyne.com

Les Nertieres 5 Avenue Hector Pintus 06610 La Gaude France

Tel. +33-49-211-0930 • Fax +33-49-211-0931 • E-mail: rdie@teledyne.com

Specifications subject to change without notice. ISO 9001:2008 certification applicable to Poway, CA facility only.
© 2009 Teledyne RD Instruments, Inc. All rights reserved. MM-1011, Rev. 12/11

