

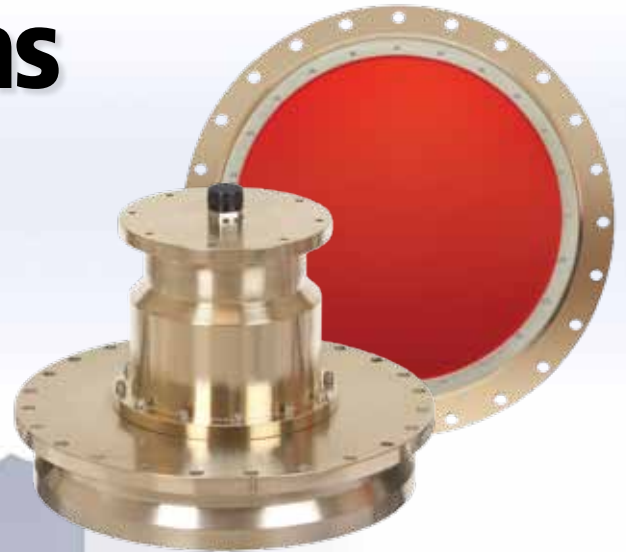

# Ocean Surveyor Vessel-Mount ADCP

LONG-RANGE 3-D CURRENT PROFILING

## Explore New Depths with Proven ADCP Technology



For over twenty-five years, Teledyne RD Instruments has been the preeminent supplier of Acoustic Doppler Current Profiling (ADCP) instrumentation for open ocean applications. Teledyne RDI's vessel-mounted **Ocean Surveyor** family of ADCPs continues to raise the bar, collecting detailed maps of the distribution of water currents and suspended materials through the water column and along the ship's path—at depths and resolutions previously considered unattainable. In real time, the ADCP is also used to aid in situ decision-making, to adapt field operations, and to understand current regime characteristics.

The Teledyne RDI Ocean Surveyor is the only vessel-mounted ADCP to incorporate:

- Broadband signal processing combined with Narrowband processing
- Patented phased array transducers, significantly reducing transducer size
- Combined current profiling, backscatter profiling, and Doppler velocity log
- Patented 4-beam design for data reliability

**Applications:**

- *Climate studies*
- *Mid-ocean frontal mapping*
- *Fisheries research*
- *Deep-water cable-laying projects*

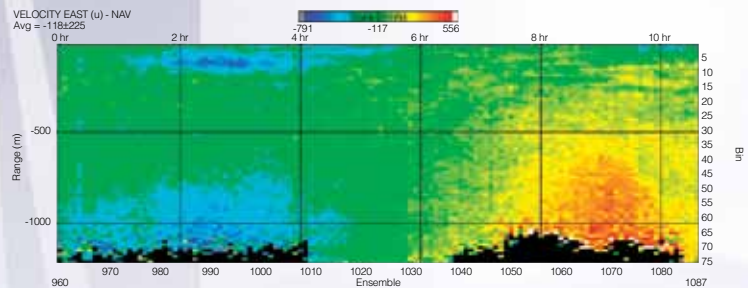

Frequency	Range	Cell Size
38kHz	800–1000m	24m
75kHz	560–700m	16m
150kHz	375–400m	8m



**TELEDYNE  
RD INSTRUMENTS**

A Teledyne Technologies Company

MEASURING WATER IN MOTION AND MOTION IN WATER

# Ocean Surveyor Vessel-Mount ADCP



## LONG-RANGE 3-D CURRENT PROFILING

### Technical Specifications

Water Profiling						
Long-Range Mode	38kHz		75kHz		150kHz	
Vertical Resolution	Max		Max		Max	
Cell Size <sup>1</sup> (m)	Range <sup>2</sup> (m)	Precision <sup>3</sup> (cm/s)	Range <sup>2</sup> (m)	Precision <sup>3</sup> (cm/s)	Range <sup>2</sup> (m)	Precision <sup>3</sup> (cm/s)
4					360–400	30
8			520–650	30	380–425	17
16	800–1000	30	560–700	17		
24	800–1000	23				
High-Precision Mode	38kHz		75kHz		150kHz	
Vertical Resolution	Max		Max		Max	
Cell Size <sup>1</sup> (m)	Range <sup>2</sup> (m)	Precision <sup>3</sup> (cm/s)	Range <sup>2</sup> (m)	Precision <sup>3</sup> (cm/s)	Range <sup>2</sup> (m)	Precision <sup>3</sup> (cm/s)
4					200–250	12
8			310–430	12	220–275	9
16	520–730	12	350–450	9		
24	600–730	9				

<sup>1</sup> Ranges at 1 to 5 knots ship speed are typical and vary with situation.

<sup>2</sup> Single-ping standard deviation.

<sup>3</sup> User's choice of depth cell size is not limited to the typical values specified.

### Profile Parameters

Velocity accuracy (typical):

±1.0%, ±0.5cm/s

Velocity range: -5 to 9m/s

# of depth cells: 1–128

Max ping rate:

38kHz: 0.5    75kHz: 0.7    150kHz: 1.1

### Bottom Track

Maximum altitude (precision <2cm/s):

38kHz    75kHz    150kHz

1700m    950m    600m

Range accuracy = <±2% actual range\*

### Echo Intensity Profile

Dynamic range: 80dB

Precision: ±1.5dB

\* Excludes errors introduced by changes in speed of sound profile, by tilting of transducer, and by slope of bottom.

 **TELEDYNE**  
**RD INSTRUMENTS**  
A Teledyne Technologies Company  
[www.rdinstruments.com](http://www.rdinstruments.com)



Free 24/7 emergency support

### Transducer & Hardware

Beam angle: 30°

Configuration: 4-beam phased array

Communications: RS-232 or RS-422

hex-ASCII or binary output at 1200–115,200 baud

### Standard Sensors

Temperature (mounted on transducer)

• Range: -5° to 45°C

• Precision: ±0.1°C

• Resolution: 0.03°

### System Power

AC input: 90–250VAC, 47–63Hz

Power: 1400W

### Environmental

Operating temperature: -5° to 40°C

Storage temperature: -30° to 80°C

### Software

Use Teledyne RDI's Windows™-based software for the best results:

- VMDAS—Vessel-mount data acquisition system
- WinADCP—Data display and export

### System Components

- 38, 75, or 150kHz transducer
- 19" rack-mount electronic chassis
- All-purpose deck box
- Gyrocompass interface board
- LCD gyro offset control display

User to supply compass input or GPS navigation data and NMEA tilt information.

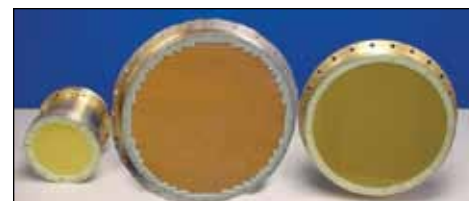

### Dimensions

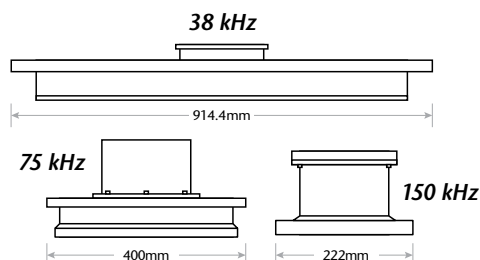

### Teledyne RD Instruments

14020 Stowe Drive, Poway, CA 92064 USA

Tel. +1-858-842-2600 • Fax +1-858-842-2822 • E-mail: [rdisales@teledyne.com](mailto:rdisales@teledyne.com)

Les Nertieres 5 Avenue Hector Pintus 06610 La Gaude France

Tel. +33-49-211-0930 • Fax +33-49-211-0931 • E-mail: [rdie@teledyne.com](mailto:rdie@teledyne.com)

Specifications subject to change without notice. ISO 9001:2008 certification applicable to Poway, CA facility only.  
© 2009 Teledyne RD Instruments, Inc. All rights reserved. MM-1021, Rev. 12/11

