

ChannelMaster H-ADCP

AFFORDABLE, HIGH-PERFORMANCE HORIZONTAL ACOUSTIC DOPPLER CURRENT PROFILER

Reliable Remote Monitoring

The compact, flexible, and affordable **ChannelMaster** is a horizontally-oriented Acoustic Doppler Current Profiler (H-ADCP) designed to collect high-accuracy water velocity, stage, and discharge data for a wide array of applications.

By leveraging Teledyne RDI's patented BroadBand technology, ChannelMaster allows you to obtain unmatched data quality, even in low velocities and complex flows, where a single cell cannot provide enough information.

The ChannelMaster's innovative design includes everything you need to collect high-quality data, without costly options. The standard unit comes equipped with temperature, pressure, pitch and roll, and a vertical beam—in many other systems these are all generally considered to be upgrades.

Only ChannelMaster provides:

- Teledyne RDI's patented BroadBand technology, which allows for small cells and/or short averaging/sampling intervals, resulting in highly accurate velocity data
- Ability to measure highly accurate velocities even in difficult environments such as slow flow or rapidly changing flow
- A range of 1–128 user-selectable cells, with cell sizes from 25cm to 8m and profiling ranges from 1m to 300m (depending on system frequency)
- A highly intuitive user interface designed to meet the needs of first-time users and seasoned researchers alike
- Standard stainless steel mounting fixture



ChannelMaster Applications:

- *Rivers, streams, and waterways:* Obtain high-accuracy data for monitoring velocity, stage, and discharge data.
- *Estuaries:* Measure complex currents for environmental monitoring or circulation model calibrations.
- *Ports and Harbors:* Monitor currents to provide accurate information for vessel maneuvering and safety.

Teledyne RDI's ChannelMaster H-ADCP is installed on a riverbank or near-shore structure to acquire real-time velocity, stage, and discharge data across a body of water.

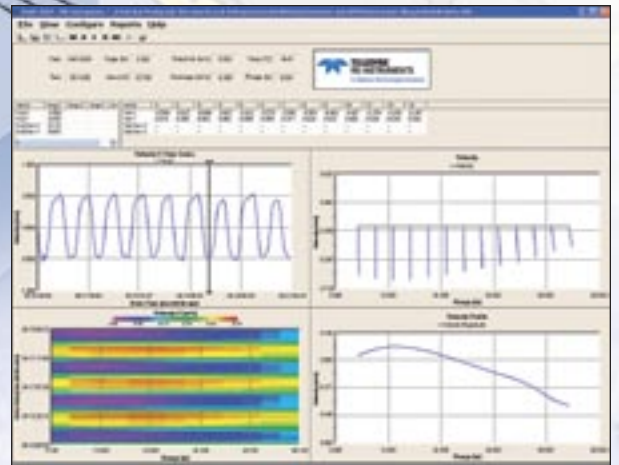

ChannelMaster H-ADCP data samples.



**TELEDYNE
RD INSTRUMENTS**

A Teledyne Technologies Company

ChannelMaster H-ADCP

HORIZONTAL ACOUSTIC DOPPLER CURRENT PROFILER

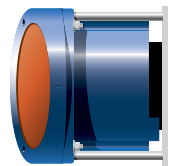

Technical Specifications

Model	300	600	1200
Velocity Profiling (BroadBand mode)			
# cells	1-128	1-128	1-128
Min. cell size	1m	0.5m	0.25m
Max. cell size	8m	4m	4m
Max. profiling range ¹	300m	90m	20m
1st cell start	2-40m	1-20m	0.5-10m
Accuracy (cell = 1/2 max.)	±0.5%	±0.5%	±0.5%
	±0.2cm/s	±0.2cm/s	±0.2cm/s
Resolution	0.1cm/s	0.1cm/s	0.1cm/s
Velocity range	±5m/s	±5m/s	±5m/s
Physical Properties			
Weight in air	6.8kg	4.76kg	3.4kg
Weight in water	3.17kg	2 kg	1.58kg
Height ²	18.3cm	18.3cm	18.3cm
Width ²	32.5cm	26.4cm	18.3cm
Depth ²	19.8cm	19.3cm	18.9cm
Transducer			
Geometry	2 beams, ±20°	2 beams, ±20°	2 beams, ±20°
Beam width	2.2°	1.5°	1.5°

¹ Maximum range depends on a number of factors, including temperature, salinity, suspended materials, etc.

² Mounted horizontally.

Dimensions

All dimensions in diagram below are millimeters [inches].

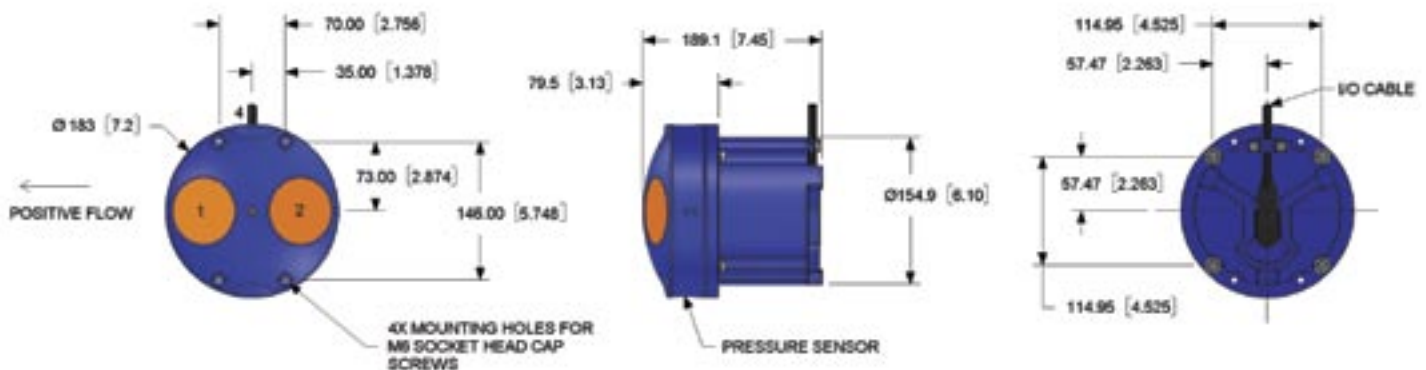

Standard Sensors

Acoustic stage:	Range 0.1-10.0m Accuracy ±0.25% Resolution 0.01cm
Pressure:	Range 0.1-10m Accuracy 0.5% Resolution 0.1cm
Temperature:	Range -4° to 40°C Accuracy ±0.2°C Resolution 0.01°
Tilt (2 axes):	Range ±10° Accuracy ±0.2° @ 0°, ±0.5° @ 10° Resolution 0.01°

Communications

RS-232 with SDI-12, or RS-422

- SDI-12 supports v 1.3 (concurrent).
- Simultaneous SDI-12, and internal logging supported.

Serial baud rates: 300-115,200 bps

Construction

Cast polyurethane with titanium hardware, mounting plate included.

Power

Voltage:	10-18VDC
Max. current:	1.5A

Note: Energy consumption depends on velocity profiling parameters. Contact Teledyne RD Instruments, or a representative, for an accurate prediction to your application.

 **TELEDYNE
RD INSTRUMENTS**
A Teledyne Technologies Company
www.rdinstruments.com

 Free online product training

 Free 24/7 emergency support

Teledyne RD Instruments
14020 Stowe Drive, Poway, CA 92064 USA
Tel. +1-858-842-2600 • Fax +1-858-842-2822 • E-mail: rdisales@teledyne.com
Les Nertieres 5 Avenue Hector Pintus 06610 La Gaude France
Tel. +33-49-211-0930 • Fax +33-49-211-0931 • E-mail: rdie@teledyne.com

